

# TG10Z0513FCS-2

**10X 5mm - 50mm F1.3**  
**for 1/3 type Cameras, Vari-focal Auto Iris DC Drive**  
**CS-Mount**

with Focus, w/o Amplifier

Model No.	TG10Z0513FCS - 2		Effective	Front	Ø29.5mm
Focal Length	5mm - 50mm		Lens Aperture	Rear	Ø8.7mm
Max. Aperture Ratio	1:1.3		Back Focal	Tele	10.6mm
Max. Image Format	4.8mm x 3.6mm(Ø6mm)			Length	Wide
Operation Range	Iris	F1.3 - F360C	Flange Back Length		12.5mm
	Focus	0.8m - Inf.	Mount		CS-Mount
	Zoom	5mm - 50mm	Filter Size		M37.5 P=0.5mm
Control	Iris	DC Auto Iris	Dimensions		Ø41.7mm x 57.5mm x 57.7mm
	Focus	Manual	Weight		140g
	Zoom	Manual			
Object Dimension at M.O.D.	5mm	77.7cm x 57cm			
	50mm	7.8cm x 6.0cm			
Angle of View	D	1/3 type	64.0° - 6.9°	1/4 type	48.8° - 5.3°
	H				39.2° - 4.3°
	V				29.5° - 3.2°
Coil	Drive	190Ω			
	Control	1000Ω			
Operating Temperature	-20°C - +50°C				

**1/3 type**

**CS**

M.O.D : Minimum Object Distance

**Dimensions**

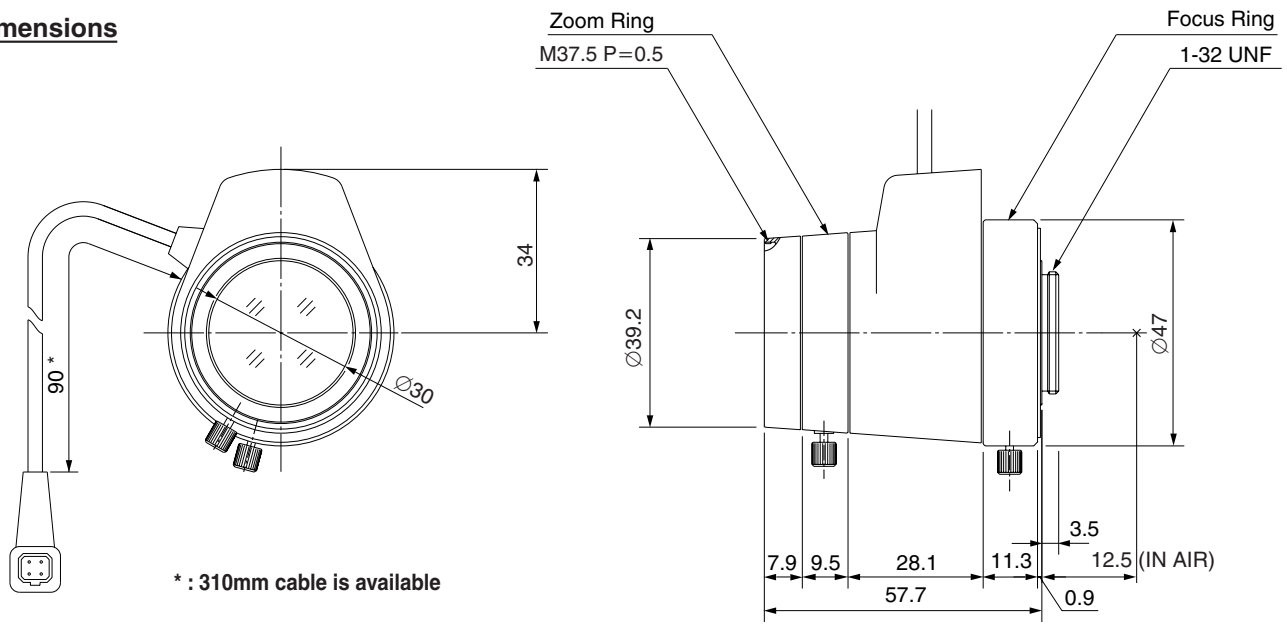

\* : 310mm cable is available

**Wiring Diagram**

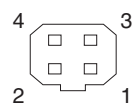

**Pin No.**

1	BROWN	Control (-)
2	RED	Control (+)
3	YELLOW	Drive (+)
4	ORANGE	Drive (-)