

TG2Z1816FCS

2X 1.8mm - 3.6mm F1.6
for 1/3 type Cameras, Vari-focal Auto Iris DC Drive
CS-Mount

with Focus, w/o Amplifier

1/3
type

Model No.	TG2Z1816FCS		Effective	Front	Ø22.0mm
Focal Length	1.8mm - 3.6mm		Lens Aperture	Rear	Ø7.9mm
Max. Aperture Ratio	1:1.6		Back Focal	Tele	10.5mm
Max. Image Format	4.8mm x 3.6mm(Ø6mm)		Length	Wide	7.0mm
Operation Range	Iris	F1.6 - F360C	Flange Back Length	12.5mm	
	Focus	0.2m - Inf.	Mount	CS-Mount	
	Zoom	1.8mm - 3.6mm	Filter Size	—	
Control	Iris	DC Auto Iris	Dimensions	Ø37.4mm x 42.6mm x 51mm	
	Focus	Manual	Weight	78g	
	Zoom	Manual			
Object Dimension at M.O.D.	1.8mm	123.8cm x 56.5cm			
	3.6mm	33.2cm x 22.9cm			
Angle of View	D	1/3 type	173.8° - 99.0°	1/4 type	135.8° - 74.4°
	H				109.5° - 59.6°
	V				82.3° - 44.7°
Coil	Drive	190Ω			
	Control	855Ω			
Operating Temperature	-20°C - +50°C				

M.O.D : Minimum Object Distance

CS

Dimensions

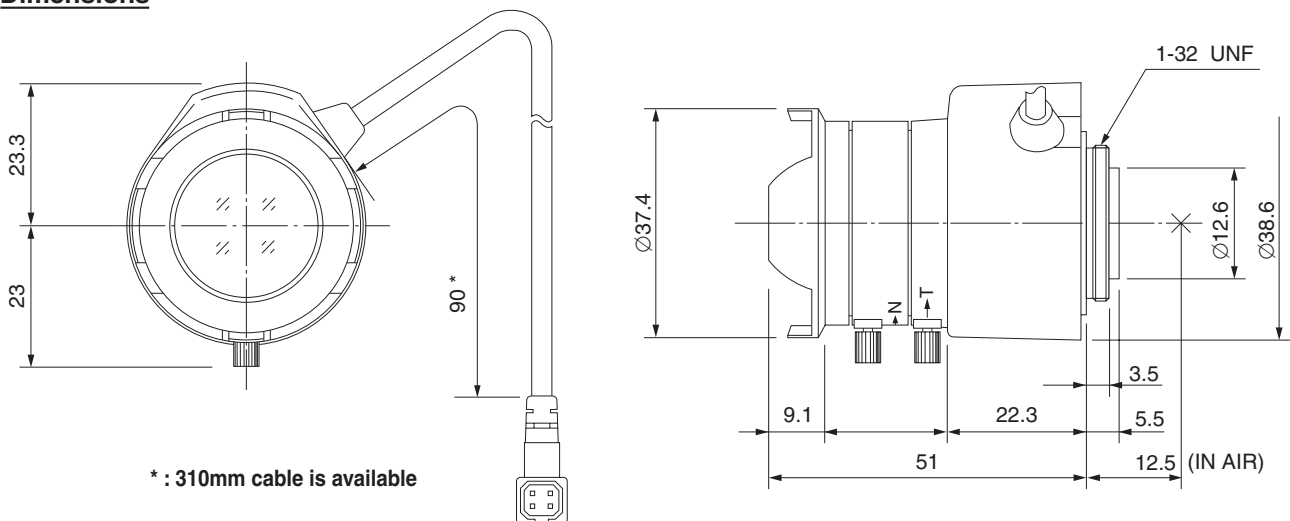

Wiring Diagram

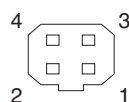

Pin No.

1	BROWN	Control (-)
2	RED	Control (+)
3	YELLOW	Drive (+)
4	ORANGE	Drive (-)